

ITEM	QTY	PART NUMBER	DESCRIPTION
1	1	DW250C	DW250C Selenic Category D Stand
2	1	DW250C TANK	250 Gallon Tank
3	8	DW250C-19	STAND CLAMP B
4	16	1B7510-500-13X0-750X035Z5	1/2-13 X .75 GRADE 5 HEX HEAD BOLT SILVER ZINC

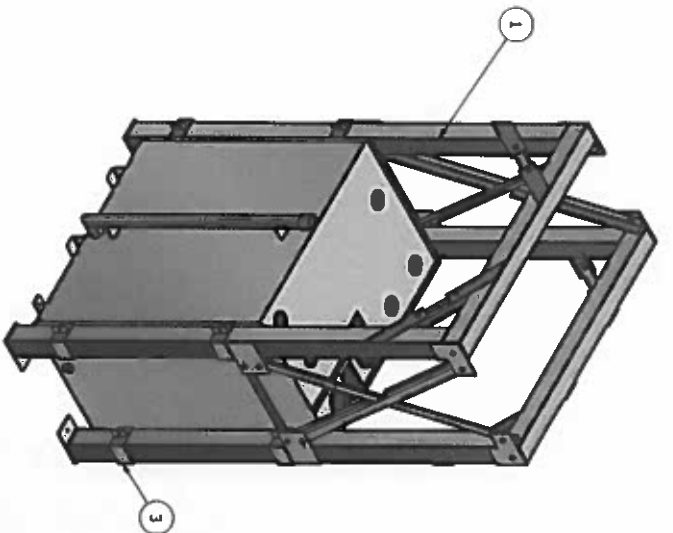
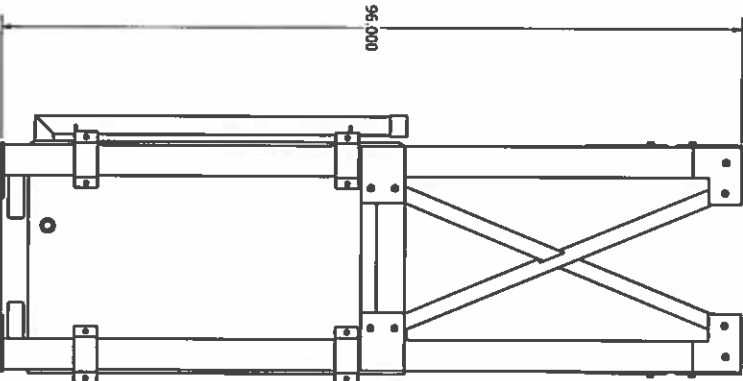
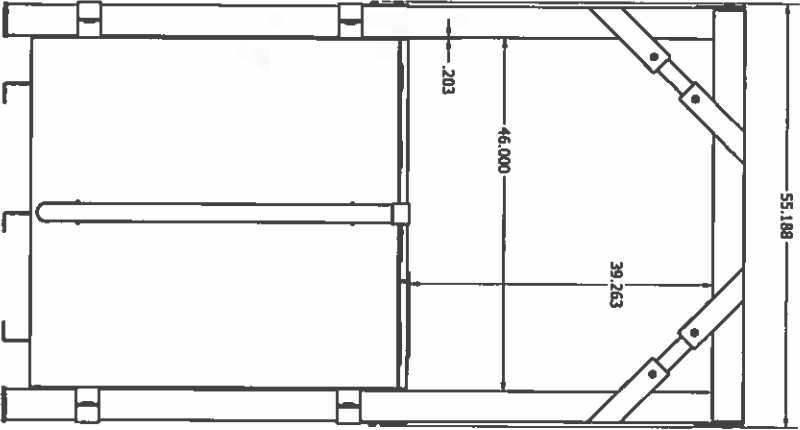
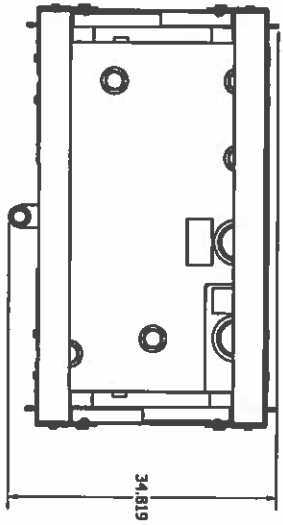

Decimal Conv
1/16 = 0.0625
1/8 = 0.125
3/16 = 0.1875
1/4 = 0.25
5/16 = 0.3125
3/8 = 0.375
7/16 = 0.4375
1/2 = 0.50
9/16 = 0.5625
5/8 = 0.625
11/16 = 0.6875
3/4 = 0.75
13/16 = 0.8125
7/8 = 0.875
15/16 = 0.9375

BREAK EDGES .01 ± .005 UNLESS OTHERWISE SPECIFIED MUST BE FREE OF BURRS WHICH MAY BE DETRIMENTAL TO SATISFACTORY ASSEMBLY, SAFE HANDLING, OR FUNCTION.

SURFACE SPECS. AS NOTED

HEAT TREAT SPECS. AS NOTED

GRIND SPECS. AS NOTED

MATERIAL DESCRIPTION:

DW250C TANK & STAND

This drawing is the property of Shurtzhaus Brothers Incorporated / SBI inc and is loaned to the recipient for the confidential use only. In consideration of the loan of this drawing, the recipient promises and agrees that it will not be used in any way detrimental to the interest of Shurtzhaus Brothers Incorporated / SBI inc. This drawing shall remain the property of Shurtzhaus Brothers Incorporated / SBI inc. Any reproduction or disclosure of this drawing or its contents without the express written consent of Shurtzhaus Brothers Incorporated / SBI inc. is strictly prohibited.

FINISH UNLESS OTHERWISE NOTED:

STOCK

MACHINING (in)	MACHINING (in)	FABRICATION (in)
0 - 5 ± 0.05	ANGLE ± 0.25°	0 - 5 ± 0.08
5 - 10 ± 0.02		5 - 100 ± 0.1
10 - 50 ± 0.04		over 100 ± 0.2
over 50 ± 0.06		

PART NO. DESCRIPTION	DRAWN	CHECKED
DW250C TANK & STAND	MART K.	
DW250C TANK & STAND		

DATE: 02/20/19

PRINT NO. DW250C TANK & STAND

SCALE: 1/12